

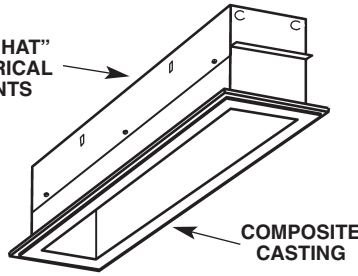

INSTALLATION INSTRUCTIONS

SLOT IN THE CEILING Individual Mounting

METAL "TOP HAT" WITH ELECTRICAL COMPONENTS



COMPOSITE CASTING

FOR SUPPLY CONNECTIONS ENTERING THIS FIXTURE USE WIRE SUITABLE FOR AT LEAST 90° C. FIXTURE IS NON I.C. RATED

* Drywall contractor must install and finish fixture composite casting joint edges and drywall seam to blend the fixture with the ceiling.

* Wiring must be done by the electrical contractor.

You MUST coordinate the two trades for bidding and installation.

These are the types of components you have for your "Slot In The Ceiling":

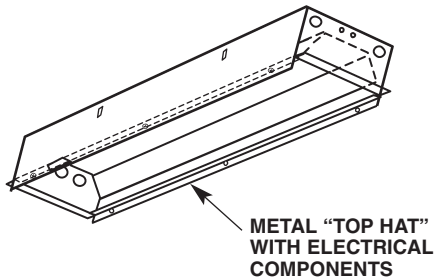

METAL "TOP HAT" WITH ELECTRICAL COMPONENTS

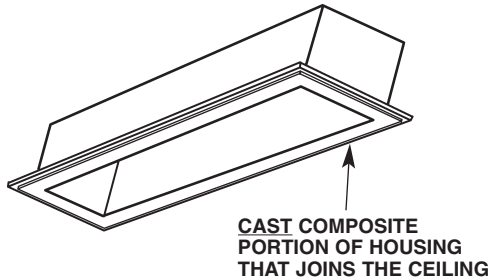

CAST COMPOSITE PORTION OF HOUSING THAT JOINS THE CEILING.

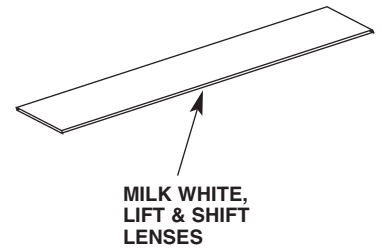

MILK WHITE, LIFT & SHIFT LENSES

Additionally you will need to supply: "Sikaflex 11-FC" Construction Adhesive (or equal), Coarse Thread 1-1/2" Drywall Screw, and Drill bits 5/32 & 7/64 sizes.

1. Frame opening with DOUBLE studs. Do NOT exceed 2" x 4" beams. Rough framed opening should be:

Casting	Dimensions
2 ft. SITC	7-1/2" W x 25-1/2" L
4 ft. SITC	7-1/2" W x 49-1/2" L

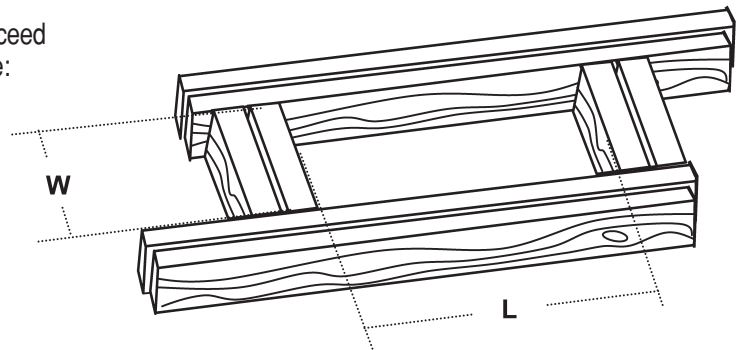

2. **PRE-DRILL MOUNTING HOLES** where indicated in the bottom of the casting pieces with **5/32" Drill Bit**. **You will break the casting if you do not pre-drill holes.**

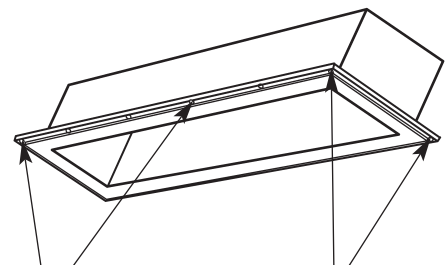

INSTALLATION INSTRUCTIONS

SLOT IN THE CEILING Individual Mounting

3. WHEN READY TO INSTALL:

- Use "SIKAFLEX 11-FC" ** construction adhesive in a healthy, 1/4" bead where indicated.
- Place casting in position between beams and secure with Coarse Thread Drywall Screws, 1-1/2".

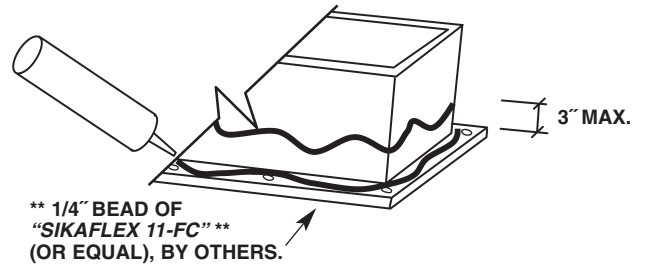

DO NOT OVERTIGHTEN OR CASTING WILL BREAK!

** ADHESIVE WILL NOT ALLOW ADJUSTMENT AFTER 30 min. — IN 73° F. Permanent after 2 hrs. (Can be sanded and painted).

- ### 4. Electrical Contractor:
- Put metal "Top Hat" fixture in place and align and secure housings together, then secure to structure through provided "Bend Down" tabs.

Attach conduit to the K.O.s in the cover plate and make wire connections. Electrical components are accessible through the fixture opening after installation.

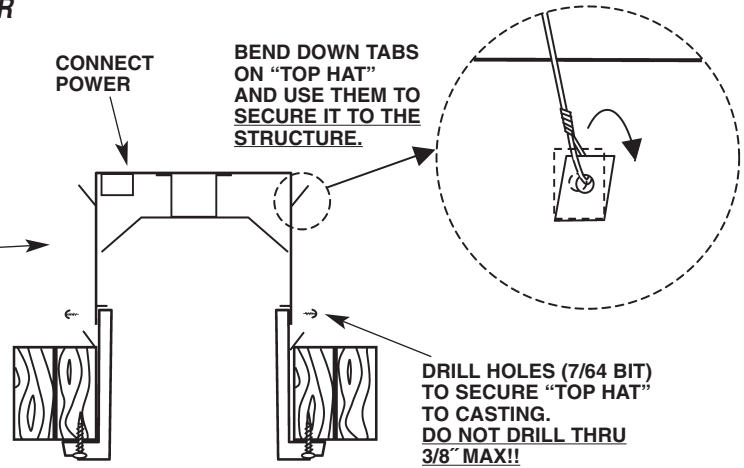

- ### 5. Drywall Contractor:
- Casting edge thickness is designed to butt up to 5/8" drywall. Close drywall ceiling. Use tape and drywall compound to finish the seams at the edge of the fixture casting.

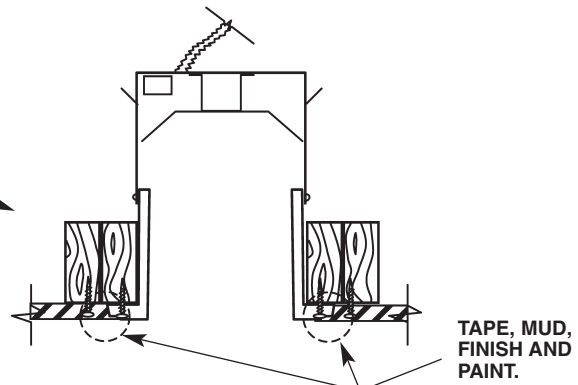

- ### 5. AFTER finish work install lamp then install Lift & Shift Lens.

